

KOMATSU®

930E-5

ELECTRIC DRIVE TRUCK



Photos may include optional equipment.

GROSS HORSEPOWER
2,700 HP 2014 kW

NOMINAL GVW
1,150,000 lb 521640 kg

930E-5

WALK-AROUND

PRODUCTIVITY FEATURES

- High performance Komatsu SSDA16V160 engine Gross Horsepower 2014 kW **2,700 HP** fully solid state AC electric drive system
- Traction (spin-slide) control
- Cruise control
- Komatsu designed application specific body
- Tight turning radius 15.8 m **51' 10"**
- Payload Meter IV®
- 4027 kW **5,400 HP** continuous retarding

ENVIRONMENTALLY FRIENDLY

- Komatsu SSDA16V160 engine with after-treatment meets U.S. EPA Tier 4 Final emissions regulations
- Fuel efficient engine
- Less fluids compared to mechanical drive trucks



Photos may include optional equipment.

HORSEPOWER

Gross: 2,700 HP 2014 kW

NOMINAL PAYLOAD

320 US tons 290 metric tons

930E-5



OPERATOR ENVIRONMENT

- Ergonomically designed spacious cab with excellent visibility
- Fully adjustable driving position settings
- Four post ROPS/FOPS level 2 cab
- User friendly display with payload information
- Komatsu Hydrair® II suspensions designed for optimum ride comfort
- AM/FM/CD/MP3/USB/weather band radio



EASY MAINTENANCE

- KOMTRAX Plus 2® allows immediate diagnostics of key engine, chassis, and drive system components
- Oil-cooled, wet disc, braking system reduces wear and extends replacement intervals
- Automatic lubrication system
- Eliminator® oil filtration system
- Flange mounted rims with optional Komatsu Smart, speed type rims
- In-tank fast fuel and DEF fill system

RELIABILITY FEATURES

- Frame design optimized for 290 tonne **320 short ton**
- Simple and reliable hydraulic system
- Steering and brake accumulators

PRODUCTIVITY FEATURES

Komatsu High Horsepower Engine

Komatsu's 2,700 HP engine will operate in most of today's mining applications without experiencing power derate. Fuel efficiency is maximized due to optimized air handling with two-stage turbocharging. Standard features include:

- A standard pre-lube system designed to reduce start-up wear and increase overhaul life.
- CENSE® on board monitoring of engine performance for each cylinder.
- ELIMINATOR® filtration system reduces oil and filter changes by as much as one-third.

AC Electric Drive System

The GTA51 traction alternator coupled with GDY106B wheel motors and Invertex IIe® AC control system provides reliable performance and easy maintenance. Invertex IIe® offers independent control of the rear wheel motors, which in turn provides outstanding traction-ability during wet and slippery conditions. This improves tire wear and increases operator confidence.

The air-cooled Insulated Gate Bipolar Transistor (IGBT) inverter system technology provides the highest available reliability. The IGBT inverter is more compact and much simpler than the design of its predecessor, the Gate Turn Off (GTO) inverter, which improves serviceability and reduces routine maintenance.

Electric Dynamic Retarder

The 4027 kW **5,400 HP** retarding system provides state of the art braking capacity for navigating today's mining applications which contain steep continuous descents and sharp switch-backs. Continuous retarding capacity enhances the productivity of the vehicle's operation, while eliminating the need for excessive mechanical braking effort.



Traction (Spin-Slide) Control

During slippery conditions, the 930E-5 wheel traction control technology detects and corrects wheel spin or slide events. Traction control operates automatically and independently of the service brakes. During propulsion, “wheel slip control” reduces non-productive wheel spin in low traction conditions. During retarding, “wheel slide control” prevents wheel lockup and subsequent sliding.

Cruise Control

Cruise control, both in propulsion and retarding, allows the operator to concentrate on steering and situational awareness while maintaining a constant speed. A set speed indicator provides confirmation the truck speed matches the desired speed selected by the operator, with simple automotive style controls.

Komatsu Designed Application Specific Body

Utilizing the required Body Worksheet (BW) process, Komatsu ensures that each body is designed to meet the requirements for specific applications while carrying its rated payload. Komatsu works with each customer to understand the material properties at a mine site and to identify the appropriate liner package.

Komatsu offers a standard all-welded steel, flat floor body with a full canopy and horizontal bolsters. This body includes a driver side eyebrow, body up sling and rubber mounts on the frame.

- Standard Body SAE Heaped 2:1: 202 m³ **264 yd³**
- Standard Komatsu Body Weight: 36228 kg **79,869 lbs**



PRODUCTIVITY FEATURES



Payload Meter IV (PLM IV®)

PLM IV® is an electronic system that monitors and records payload information for Komatsu's off-highway mining trucks. The accurate and reliable payload measurement system is designed to help optimize payload, maximize productivity and reduce the life cycle cost of the machine. PLM IV® tracks and records the following key production parameters:

- Payload
- Empty Carry-Back
- Operator Identification
- Haul Cycle, Loading, Dumping Time and Date
- Distance Traveled (Loaded and Empty)
- Cycle Time Information
- Maximum Speeds (Loaded and Empty)
- TMPH Estimate for Front and Rear Tires
- Average Speed (Loaded and Empty)

Tight Turning Radius

By using double acting hydraulic steering cylinders with a six-point articulation linkage, the 930E-5 power steering system provides positive steering control with minimal operator effort. The ISO 7457 turning circle diameter of the 930E-5 is 32 m **105'**, which provides excellent maneuverability for tight loading and dumping conditions. The steering accumulators comply with ISO-5010 standards.

Hydrair II® Hydropneumatic Suspension

Hydrair II® is a suspension system that utilizes four nitrogen-over-oil cylinders. This suspension system is designed to maximize machine productivity by providing the operator with a smooth and comfortable ride. By absorbing shocks to the chassis during operation, Hydrair II® contributes to the durability of the machine's frame and components.



OPERATOR COMFORT

Operator Seat

Komatsu recognizes that operator comfort is a key to productivity in today's mining environment. The five-way adjustable operator seat and the tilt-telescopic steering column provides an optimum driving posture for increased operator comfort and control over the machine. The air suspension seat absorbs vibrations transmitted from the machine, reducing operator fatigue. A 51 mm 2 in wide, blaze orange, three-point seat belt is provided as standard equipment.

Built-in ROPS and FOPS Structure

These structures conform to ISO standards 3471 and 3449.

Ergonomically Designed Cab

The Komatsu 930E-5 cab design provides a comfortable and productive environment to meet today's mining demands. The cab includes tinted safety glass windows, heating and air conditioning, acoustical insulation, double sealed doors and filtered, pressurized air to reduce dust.

User Friendly Display

The 930E-5 comes with a new operator friendly dash configuration which includes lighted gauges, switches and information panel. This allows the operator to see the status of the machine during operation and informs them of any faults. An instructive message will appear after any fault is detected on the machine.



Photo may include optional equipment.

TIER 4 AND ELECTRIFICATION

930E-5

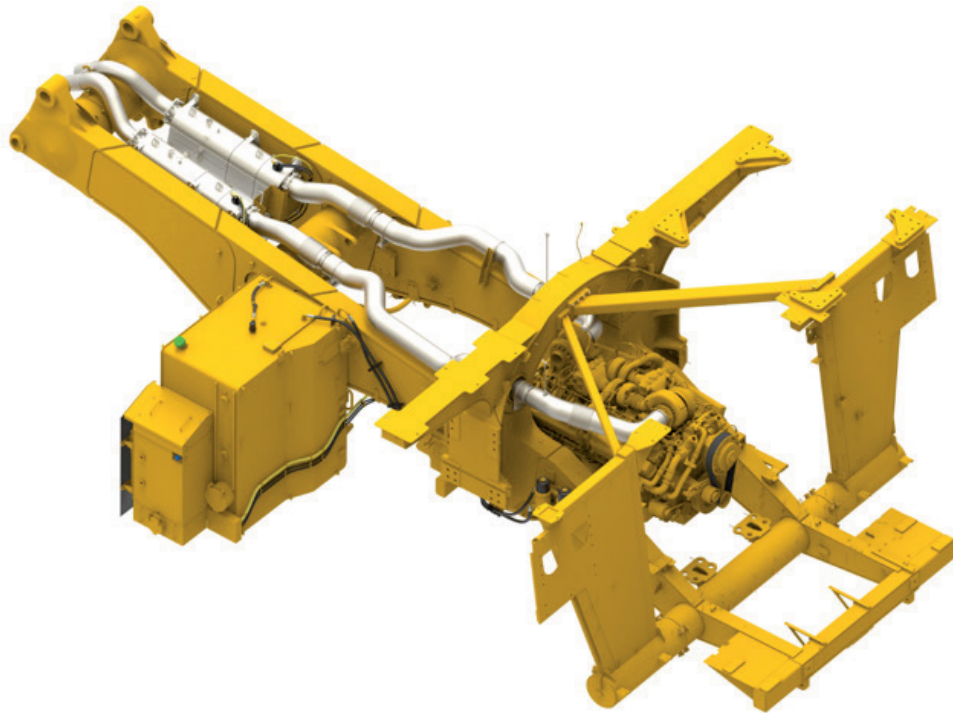

Evolutionary, not Revolutionary Design

Komatsu's Tier 4 solution begins with a base engine which is very similar to the previous Tier 2 platform. In keeping the basic operation of the engine the same, durability is assured. Utilizing High Pressure Common Rail fuel delivery ensures atomization of the fuel/air mixture to a level which reduces particulate matter, meeting U.S. EPA Tier 4 standards.

Komatsu After-treatment

Removal of NOx is accomplished by treating the exhaust through Selective Catalytic Reduction (SCR). The introduction of Diesel Exhaust Fluid (DEF) into the SCR canister generates a chemical reaction which breaks down the oxides of nitrogen into oxygen and nitrogen, both non-pollutants. Internal cleaning of the SCR is performed through an automatic process.

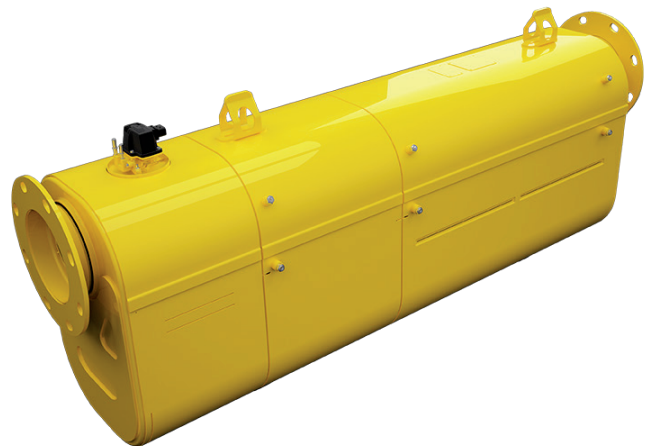

On-Demand Cooling

- Separate cooling circuits for control group and wheel motor systems
- Allows intelligent control of cooling
- Maintain optimal temperatures for each system

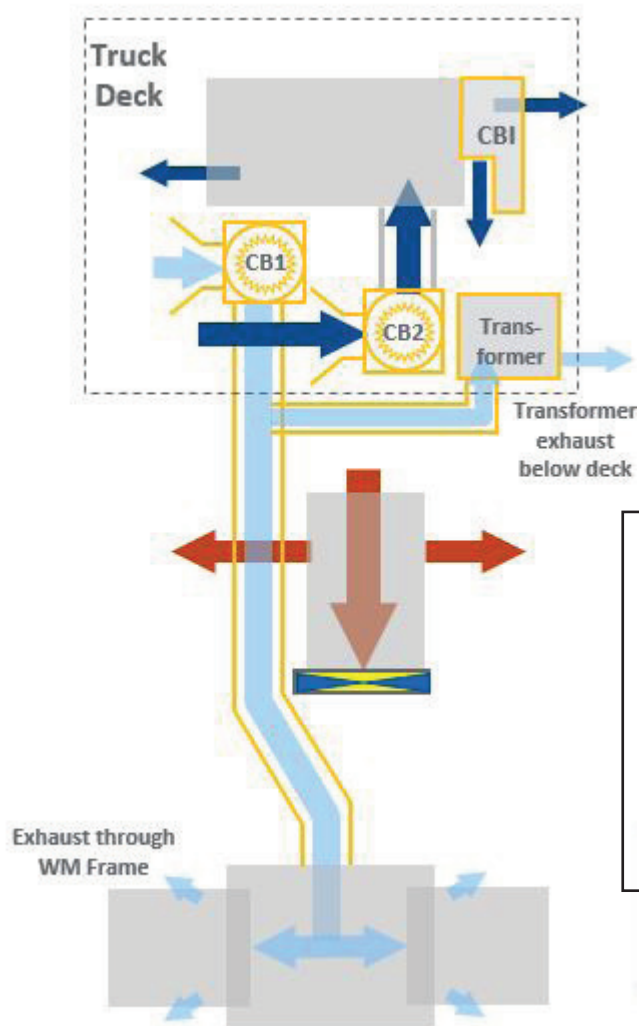

Alternator Self-Cooling Only

- Reduced impeller size by 25%
- Reduced cooling housing/impeller
- 500 lb 227 kg weight reduction

Uses Wheel Motor generator retarding energy for cooling

- Control Group
- Wheel Motors
- Grid Blower

RELIABILITY FEATURES

Structurally Enhanced Frame Design

By using advanced computer-aided design, finite element analysis and full-scale dynamic and static testing, the frame has been designed to carry 290 metric tons 320 short tons and provides the high structural reliability Komatsu is known for.

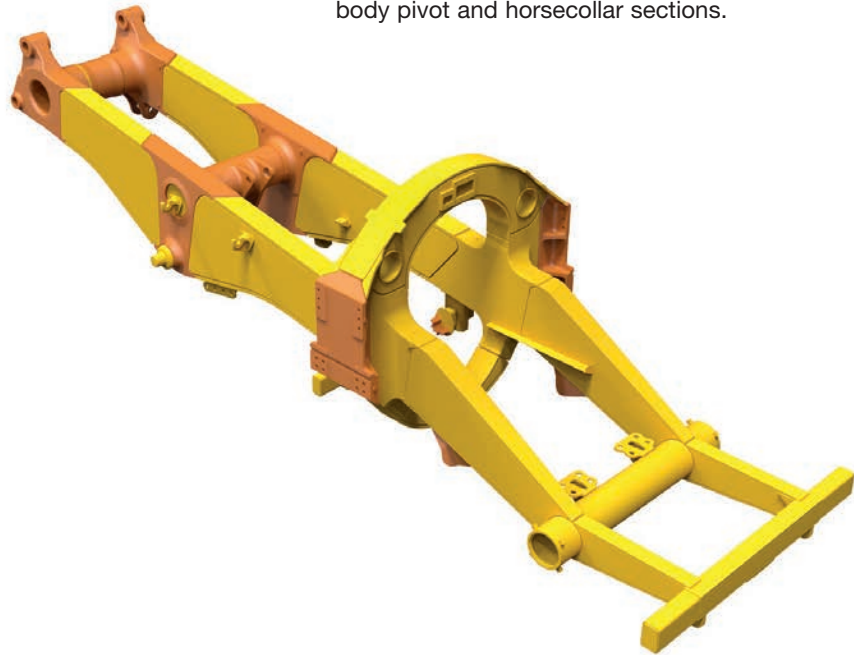

Castings in High Stress Areas

To increase frame reliability, steel castings have been incorporated at key frame pivot points and critical load bearing portions of the structure. This includes the rear body pivot and horsecollar sections.

Simple and Reliable Hydraulic System

The hydraulic system is a proven and reliable design with fewer parts than other OEMs. The system utilizes a single tank, providing one common source of fluid for steering, braking and hoisting. In-line replaceable filtration elements provide protection from hydraulic system contamination, making the system easier to service.

To keep downtime to a minimum, Komatsu developed a sub-frame pump module that can be removed and replaced as a single unit. This reduces change-out time and allows easy access to the hydraulic pump module.

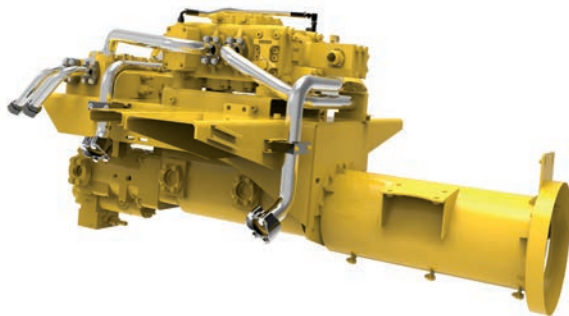

Proven Wheel Motor Design

The GDY106B Wheel Motor builds on the success of its predecessor. Held to the highest standards, the transmission and motor were subjected to extensive testing and quality confirmation. A full scale controlled durability and field test was conducted at Komatsu's Proving Grounds during development to confirm design quality prior to production. By using planetary design, extensive machining is not required during a standard rebuild.

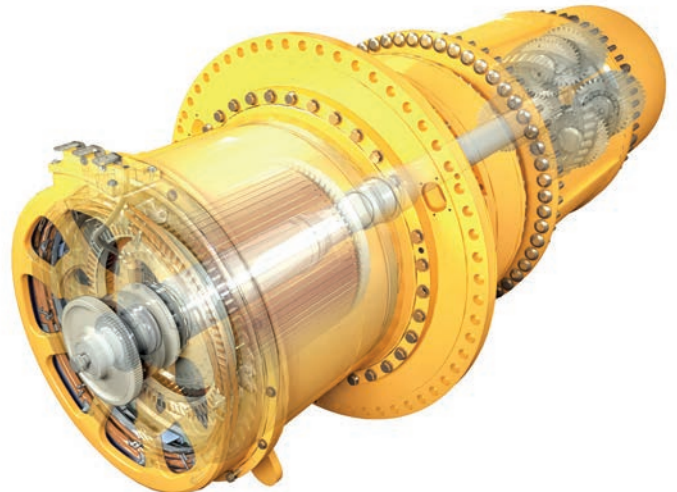

Fully Hydraulic Controlled Multiple-Disc Wet Brakes

While the dynamic retarding system is the primary braking force, the 930E-5 comes standard with four-wheel, hydraulically actuated, oil-cooled service brakes. In the event that the truck's hydraulic system pressure drops below an acceptable level, the accumulators will automatically apply all wheel brakes to bring the truck to a complete stop.

- Max. service apply pressure: 17237 kPa **2,500 psi**
- Total friction area per brake: 97025 cm² **15,038 in²**

The oil-cooled brake system provides lower maintenance costs and higher reliability versus dry disc brakes. This system is fully sealed to help keep contaminants out and reduce brake wear and maintenance. The brakes are hydraulically actuated; no pneumatic system is used. There are three independent hydraulic circuits that provide hydraulic back-up.

The 930E-5 stops within the required distance as stipulated by ISO 3450.



EASY MAINTENANCE

Access, Service and Convenience

Located on the front left bumper adjacent to the main entry to the machine, Komatsu installs many service and convenience items. This central location simplifies maintenance events, reducing the time the truck is out of service for routine upkeep.

1. Auto-lubrication tank and controls
2. Power, starter and drive system lockout (lock-out/tag-out capable switches)
3. Emergency engine shut-down
4. Fluid service center (coolant, engine oil, hydraulic oil, grease fill)
5. Hydraulic step up/down switch (Hydraulic stairs are optional)



KOMTRAX Plus 2®

As part of a complete service and support program, Komatsu equips every mining and quarry sized machine with KOMTRAX Plus 2®. By using a satellite-based communication system, KOMTRAX Plus 2® offers a new vision of monitoring your valuable assets. By providing insight to critical operating metrics the user can manage increased availability, lower owning and operating costs and maximize fuel efficiency.

The information available through KOMTRAX Plus 2® allows service personnel to review faults and trends, improve the quality of the troubleshooting process and reduce unscheduled machine downtime.



Flange Type Tire Rims

Komatsu Smart rim technology allows easy removal and installation of the tires to minimize the overall impact on downtime.

Smart Type Rim (7 Piece Type Rim components)

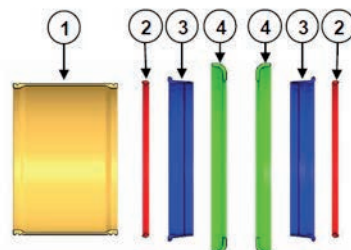

ITEM	QTY	DESCRIPTION
1	1	Rim Base
2	2	Smart Lock Ring
3	2	Bead Seat Band
4	2	Side Ring

DRIVE SYSTEM

Drive System (Invertex IIe)

- Cooling Blower Inverters (CBI)
- True Quad Chopper Eliminates RP Contactors
- Only Single Stack IGBT's
- From 24 to 12 Traction IGBT's Reduces Weight & Size
- Meets IP54 for Dust & Moisture Control
- Increased Cabinet Rigidity
- Reduced Rigid Multi-axis Joints
- Fiber Optic Cards Integrated Into Backplane
- Front Placement of Indicator & Interface Panels
- Front Access for Maintenance
- All LED Lighting

Improved Bus Bar

- Close Molded Design- Eliminates Potting
- No Soldered Bushings
- Edge Protection
- FR4 & Abrasion Protection
- Simplified, More Robust Bus Bar Design

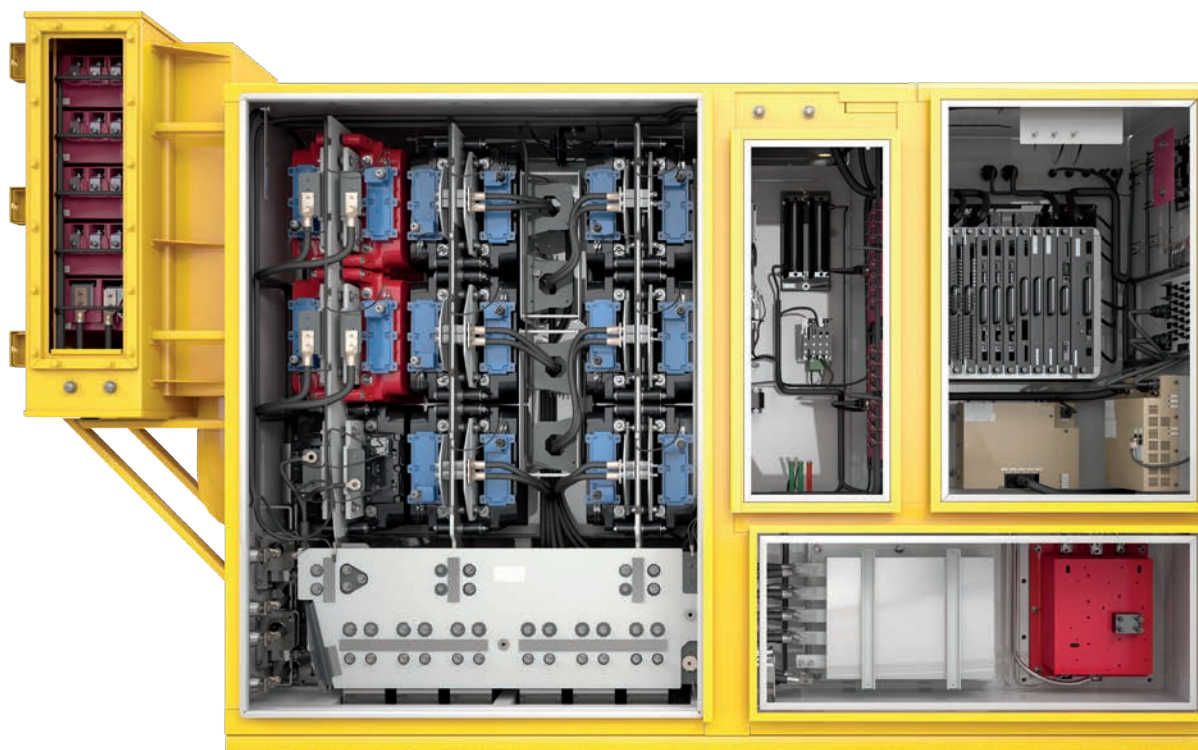

DRIVE SYSTEM

Improved Truck Performance

- Retains Wheel Slip/Slide control in all Modes of Operation
- Cruise Control (Both Motoring & Retarding)
- Fuel Saver 2 Built-in

Technology Advancements

- Supports Data Collection & Transmission for Remote Monitoring
- New Generation Technology for Faster Processing with Higher Capacity (90% Faster Data Transfer)
- Common CAN Network Consists of Engine, Truck & Drive System
- Supports CAN, Ethernet & USB

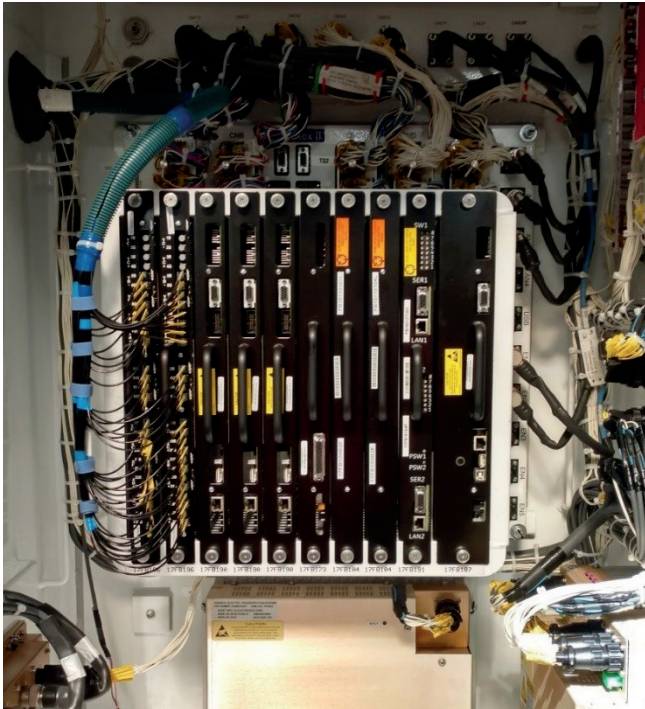

VID Display

- Replaces DID Panel
- In-cab Touch Screen Display for Setup, Maintenance & Troubleshooting
- Access, Download & Update System from the Operators Cab
- Entry to Control Cabinet no Longer Required for Basic Troubleshooting

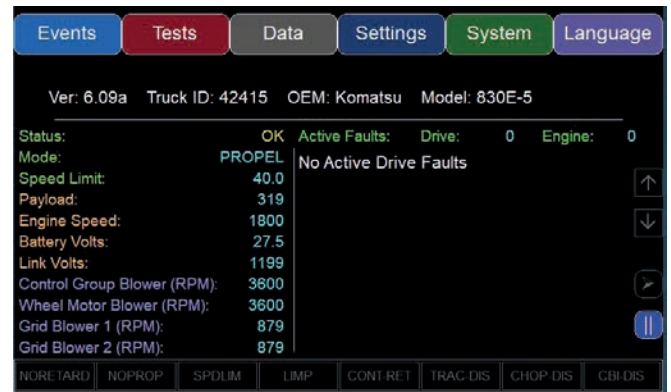

WebPTU

- Replaces wPTU
- Primary Maintenance & Troubleshooting Tool for all Future Systems
- Browser Based Access & Visualization of Truck System Data
- Eliminates Dependency on Legacy PC's & Operating Systems
- Accessible in Operators Cab via Ethernet

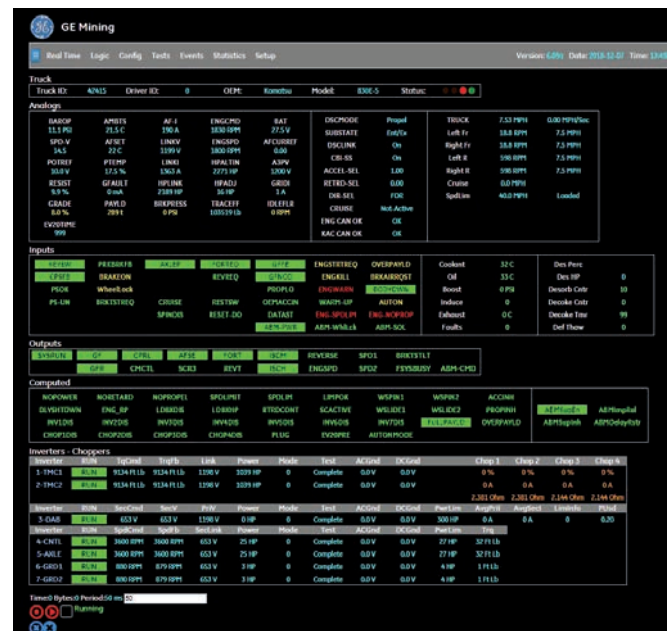

ADDITIONAL FEATURES

Environmentally Friendly

Less Fluids than Mechanical Drives

Komatsu electric drive trucks contain 57% less hydraulic fluid compared to similar class mechanical drive trucks, creating a lower environmental impact and makes fluid replacement simpler, quicker and more economical.

U.S. EPA Compliant

The Komatsu SSDA16V160 engine is compliant with the U.S. EPA Tier 4 emissions regulations.

Reduced Fuel Consumption

The engine and drive system are specifically tuned together, providing efficient power usage and minimizing fuel consumption.

Komatsu Loading Policy for Mining Trucks

In normal loading operations, variations in payloads occur. The loading policy identifies the guidelines and limitations for the loading of those Komatsu Mining Truck models specified.

Definitions:

- **Rated GVW** (Gross Vehicle Weight) includes the chassis, body, tires, accessories (including local options), lube, fuel, operator, payload and any excess material build-up.
- **Rated Payload** is the resultant difference of Rated GVW minus EVW.
- **Overload** refers to any payload amount in excess of the Rated Payload.
- **Never to exceed GVW** is the maximum allow able GVW under the guidelines of this Policy.

Actual payloads greater than the Rated Payload are allowable, but shall not result in a GVW that is greater than the Never to Exceed GVW.

No single payload that results in a **GVW** in excess of the Never to Exceed GVW is allowed under any circumstances.

The mean of all payloads for a rolling 30-day period shall not exceed the Rated Payload.

Truck Model	930E-5	
Specification	lb	kg
Rated GVW	1,150,000	521,640
Standard Tire Size	53/80R63	
Rated / Nominal Payload	640,000	290,299
Never To Exceed GVW	1,278,000	579,688

SPECIFICATIONS



ENGINE

Make and model.....	Komatsu SSDA16V160
Fuel	Diesel
Number of cylinders	16
Operating cycle	4 cycle
Gross horsepower*.....	2014 kW 2,700 HP @ 1800 rpm
Net flywheel power**.....	1930 kW 2,588 HP @ 1800 rpm
Weight (wet)	8966 kg 19,767 lb
Weight (dry)	8471 kg 18,675 lb

* Optional Tier 4 emissions compliant engine for North American market. Non-emissionized engine for markets outside of North America

* Gross horsepower is the output of the engine as installed in this machine, at governed rpm and with engine manufacturer's approved fuel setting. Accessory losses included are water pump, fuel pump and oil pump.

**Net flywheel power is the rated power at the engine flywheel minus the average accessory losses. Accessories include fan and charging alternator. Rating(s) represent net engine performance in accordance with SAE J1349 conditions.



ELECTRIC DRIVE

AC/DC CURRENT

Alternator	GTA-51
Dual impeller in-line blower	71.2m ³ /min 2,515 cfm
Control	AC Torque Control System
Motorized wheels*	GDY106-B Induction Traction Motors
Ratio.....	32.62:1
Speed (maximum)	64.5 km/h 40 mph

* Drive system performance depends upon gross vehicle weight, haul road grade, haul road length, rolling resistance and other parameters. Komatsu must analyze each job condition to assure proper application.



TIRES AND RIMS

Rock service, tubeless, radial tires	
Standard tire*.....	53/80 R63
Flange mount, five piece rim	
914 mm x 1600 mm x 127 mm	36" x 63" x 5.0" rim assembly.
Rims rated at 758 kPa	110 psi cold inflation pressure.

Typical tire weight

* Tires should meet application requirements for tkph/tmph, tread, compound, inflation pressure, ply rating or equivalent, etc.

* Tires sold separately.



CAB

Advanced Operator Environment with integral 4-post ROPS/FOPS Level 2 structure (ISO 3449), adjustable air suspension seat w/ lumbar support and arm rests, full-size passenger seat, maximum R-value insulation, tilt and telescoping steering column, electric windshield wipers w/washer, tinted safety glass, power windows, Payload Meter IV, 55,000 Btu/hr heater and defroster, 21,600 Btu/hr air conditioning (HFC - 134A refrigerant).



SUSPENSION

Variable rate hydro-pneumatic with integral rebound control	
Max. front stroke	328mm 12.92"
Max. rear stroke	239 mm 9.40"
Max. rear axle oscillation	±6.5°



FRAME

Advanced technology, full butt-welded box sectional ladder-type frame with integral ROPS supports, integral front bumper, rear tubular cross members, steel castings at all critical stress transition zones, rugged continuous horsecollar.

Plate material.....	482.6 mPa 70,000 psi
	tensile strength steel
Casting material.....	620.5 mPa 90,000 psi
	tensile strength steel
Rail width.....	305 mm 12"
Rail depth (minimum)	864 mm 34"
Top and bottom plate thickness.....	45 mm 1.77"
Side plate thickness.....	25 mm 0.98" Rear
	32 mm 1.26" Front
Drive axle mounting	Pin and spherical bushing
Drive axle alignment.....	Swing link between frame and axle



BODY

All-welded steel flat floor body with horizontal bolsters and full canopy. Rubber mounts on frame, eyebrow and body up sling are standard. Extended canopy and pivot exhaust heating are optional.

Floor sheet	16 mm 0.63" Outer 19 mm 0.75" Center
	1379 MPa 200,000 psi tensile strength steel
Front sheet	10 mm 0.39" Outer 12 mm 0.47" Center
	1379 MPa 200,000 psi tensile strength steel
Side sheet	8 mm 0.39" 1379 MPa
	1379 MPa 200,000 psi tensile strength steel
Canopy sheet	6 mm 0.24" 690 MPa
	689 MPa 100,000 psi tensile strength steel
SAE heaped 2:1	202 m ³ 264 yd³
Standard Komatsu body weight	36228 kg 79,869 lb



BRAKING SYSTEM

Service brakes.....	Oil-cooled, hydraulic
	actuated, multiple disc brakes at each wheel
Traction system	wheel spin-slide control
Max. service apply pressure	7237 kPa 2,500 psi
Total friction area per brake.....	97025 cm ² 15,038 in²
Auto apply system.....	Automatically applied prior to hydraulic
	system pressure dropping below level required to meet secondary
	stopping requirements
Secondary brake system	Complies with ISO-3450 Standards
Wheel brake lock	Switch activated
Parking brakes	Multiple disc,
	spring-applied, hydraulically-released, dry brakes on inboard end
	of each wheel motor rotor shaft. Rated to hold on ±15% grade at
	maximum gross vehicle weight.
Electric dynamic retarder	4026 kW 5,400 hp



COOLING SYSTEM

L&M radiator assembly, split-flow, with deaerator-type top tank.	
Radiator frontal area	7.02 m ² 75.5 ft²

Dimensions are in meters

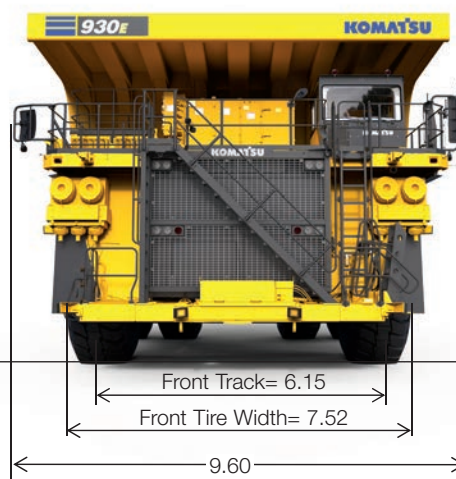
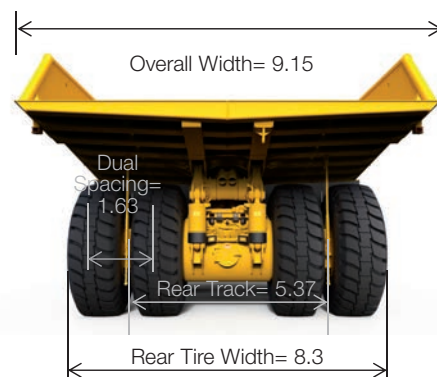
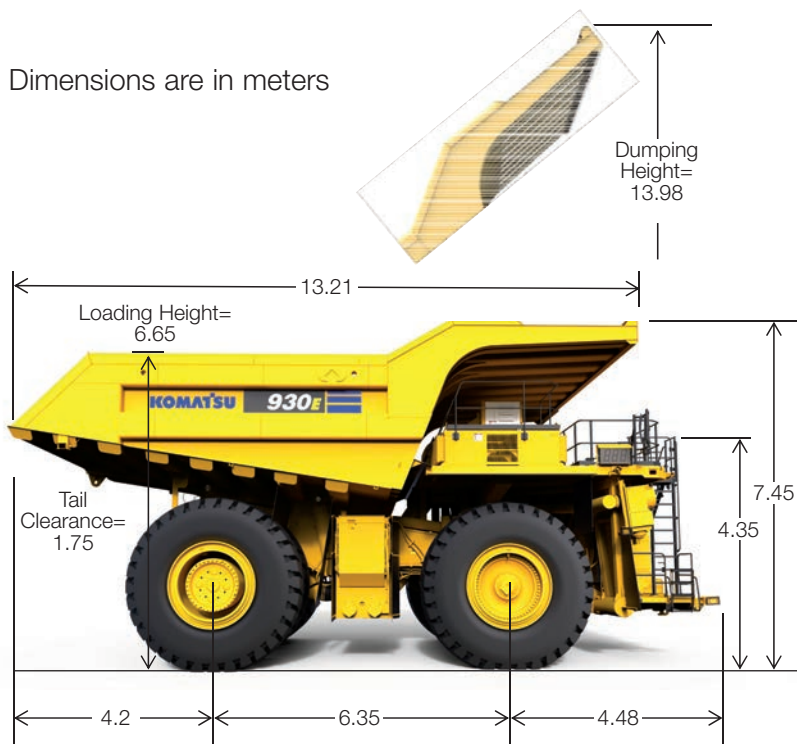

HYDRAULIC SYSTEM

- Steering.....Accumulator assisted with twin double acting cylinders provide constant rate steering. Secondary steering automatically supplied by accumulator.
- Turning circle diameter (SAE)32 m **105'**
- Reservoir947 L **250 U.S. gal**
- Filtration.....In-line replaceable elements
 - Suction Single, full-flow, 100 mesh
 - Hoist and steeringDual, in-line, high pressure
- Brake component cabinet.....Above deck, easily accessible with diagnostic test connections
- HoistTwo 3-stage dual acting outboard cylinders, internal cushion valve, over-center dampening
- Hoist times
 - Power-up loaded 21 sec
 - Power-down 12 sec
 - Float-down empty..... 18 sec
- PumpsTwo pumps, single package, in-line
- Hoist and brake coolingTandem gear pump with output of 931 lpm **246 gpm** at 1900 rpm and 22063 kPa **3,200 psi**
- Steering and brakeVariable displacement piston pump with output of 246 lpm **65 gpm** at 1900 rpm
- System relief pressures
 - Hoist and brake cooling17237 kPa **2,750 psi**
 - Steering and brake27579 kPa **4,000 psi**
- Ports available for powering disabled truck and for system diagnostics

Body	Capacity		Loading Height*
	Struck	2:1 Heap	

Standard 151 m³ **197 yd³** 202 m³ **264 yd³** 6.65 m **21'10"**

*Exact load height may vary due to tire make, type, and inflation pressure.



ELECTRICAL SYSTEM

- 4 x 8D 1400 CCA, 12 volt, in series/parallel, 220 ampere-hour, bumper-mounted with disconnect switch & lock-out.
- Alternator 24 volt, 275 amp
- Lighting 24 volt
- Cranking motorsTwo/24 volt



SERVICE REFILL CAPACITIES

Cooling System	568 L	150 U.S. gal
Crankcase	363 L	95.8 U.S. gal
Hydraulic system	1325 L	350 U.S. gal
Motor gear box (each)	57 L	15 U.S. gal
Fuel tank	4542 L	1,200 U.S. gal
DEF tank	288 L	76 U.S. gal

SPECIFICATIONS

Truck Performance Graph

930E-5 PERFORMANCE 2,700 HP - 53/80 R63 Tires

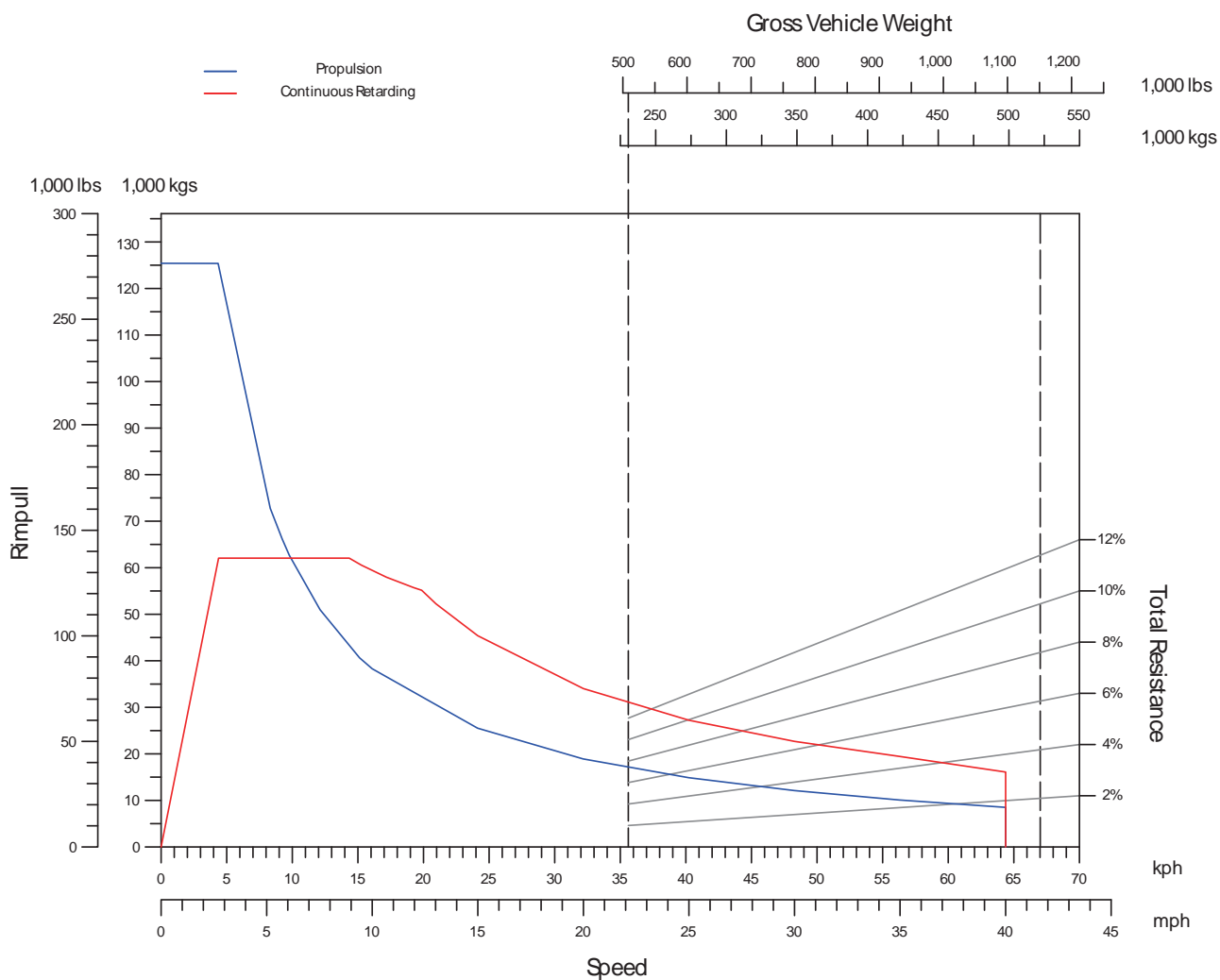

Empty Vehicle Weight*

Front Axle Distribution	108181 kg	238,500 lbs	48%
Rear Axle Distribution	123150 kg	271,500 lbs	52%
Total EVW	231331 kg	510,000 lbs	

Gross Vehicle Weight

Front Axle Distribution	172141 kg	379,500 lbs	33%
Rear Axle Distribution	349499 kg	770,500 lbs	67%
Nominal GVW	521640 kg	1,150,000 lbs	

Payload

Nominal Payload	290000 kg	640,000 lbs	
	290 metric tons	320 short tons	

Nominal payload is defined by Komatsu America Corp's payload policy documentation. The figures above are provided for the basic product description purposes. Please contact your Komatsu distributor for specific application requirements.

*Includes option allowance





STANDARD EQUIPMENT

- Air cleaners, Donaldson® SSG w/ auto evacuators
- Alternator (Charging 24 volt/250A)
- Automatic lubrication system w/ground level fill, level indicator & dynamic timing
- Back-up alarm
- Batteries—4 x 8D (1450 CCA's)
- Battery charging/jump start connector
- Body over-center device
- Body-up sling (w/KAC supplied body)
- Brakes: oil-cooled, multiple disc front & rear
- Electric start
- Eliminator®, Cense®
- Fast-fill fuel system (in tank and left side remote)
- Filters, high pressure hydraulic
- Ground level radiator fill
- Mirrors, heated, multi-cambered convex LH & RH
- Mud flaps
- Muffled exhaust—deck-mounted
- Power supply, 24 volt to 12 volt DC
- Quick disconnects (steering, hoist and diagnostics)
- Retard speed control w/set indicator
- Radiator sight gauge
- Removable power module unit (radiator, engine, alternator)
- Reverse retarding
- Service center—LH
- Thermostatic fan clutch

OPERATOR ENVIRONMENT & CONTROL:

- All hydraulic service brakes with auto apply
- Battery disconnect switch
- Brake lock and drive system interlock
- Circuit breakers, 24 volt
- Diagonal staircase across grille
- Dynamic retarding with continuous rated element grids
- Engine shutdown at ground level
- Hoist propulsion interlock

- Horns (electric—front)
- Integral ROPS/FOPS Cab Level 2
- Maintenance and power lockout
- Parking brakes with warning light & speed application protection
- Power steering w/auto secondary steering
- Protective deck handrails
- Pump driveline protector
- Radiator fan guard
- Seat belts
 - Operator 3-point 51 mm 2" retractable
 - Passenger lap 51 mm 2" retractable
- Slip-resistant walkways

STANDARD HIGH VISIBILITY DELUXE CAB:

- AC drive interface display
- Air conditioner HFC-134A
- AM/FM radio with CD, USB & MP3
- Dome light
- Electronic Dash & Status Panel
 - Body up
 - Engine oil temperature (high)
 - Parking brake
 - Propulsion system not ready
 - No DC link voltage
 - No propel
 - Service brake applied
 - Wheel brake lock applied
 - Maintenance monitor
- Engine hourmeter, oil pressure gauge, coolant temperature gauge, hydraulic oil temperature gauge
- Engine shutdown w/ "Smart Timer" delay
- Floor mat (double barrier)
- Fuel gauge in cab
- Fuel low level light and buzzer
- Gauges (w/backlight)
- Headlight switch
- Heater and defroster (heavy-duty)
- Heater switch

- High beam selector and indicator
- Horn switch (center of steering wheel)
- Indicator lights (blue)
 - Engine service
 - Komtrax Plus 2® snapshot (IM)
- Komatsu Payload Meter IV
- Komtrax Plus 2®
- Operator seat, adjustable w/air suspension, lumbar support and arm rests
- Panel lighting (adjustable)
- Passenger seat, mechanical suspension
- Power windows
- Pressurized cab air system w/fan on
- Single brake/retarder pedal
- Sunvisor (adjustable)
- Tilt & telescoping steering column
- Voltmeter (battery output)
- Windshield (tinted safety glass)
- Windshield wiper (dual) and washer (electric)

LIGHTING:

- Back-up lights—rear mount (2) halogen
- Back-up lights—R and L- deck mount (2) halogen
- Brake and retard lights on top of cab
- Clearance lights (LED)
- Dynamic retarding, rear (2) (LED)
- Engine compartment service lights
- Fog lights (2) halogen
- Headlights (8) halogen
- Manual back-up light, switch and indicator
- Payload lights R and L (LED)
- Stairway lights
- Stop & tail lights (2) (LED)
- Turn signals (LED)



OPTIONAL EQUIPMENT

Note: Optional equipment may change operating weight.

- Amber Beacon Light
- Application Specific Body Structure
- Body liners
- Body up sling
- Bumper Access Hydraulic Retractable Stairs
- Bumper Mounted Headlights
- Double Wall Exhaust Tubes
- Engine Access Platform-LH
- Extended canopy
- Eyebrow
- Fire extinguisher 9 kg **20 lb**

- Heated body
- Hot start engine oil (220V 2-500W)
- Hot start hydraulic oil
- Hot start engine coolant (220V 2-2500W)
- Hubodometer
- Komatsu Smart Rims
- Komvision All-Around Monitoring System
- LED Headlights
- Lights (HID)
- Mufflers between frame rails (standard Tier IV)
- PLM IV® scoreboards

- Premium Operator Seat
- Reversed access ladder
- Service center—RH
- Shutters (radiator)
- Spare Rim
- Spare Smart Rim
- Special language decals
- Suspensions (cold weather)
- Rock Ejectors

AESS921-01

©2019 Komatsu America Corp.

Printed in USA

01/19 (EV-1)

KOMATSU®

Note: All comparisons and claims of improved performance made herein are made with respect to the prior Komatsu model unless otherwise specifically stated.



www.komatsuamerica.com

Komatsu America Corp. is an authorized licensee of Komatsu Ltd. Materials and specifications are subject to change without notice

KOMATSU®, Komatsu Care® KOMTRAX® and KOMTRAX Plus 2® are registered trademarks of Komatsu Ltd.

All other trademarks and service marks used herein are the property of Komatsu Ltd., Komatsu America Corp. or their respective owners or licensees.

930E-5